

CONDITIONS OF USE FOR THIS PDF

The images contained within this PDF may be used for private study, scholarship, and research only. They may not be published in print, posted on the internet, or exhibited. They may not be donated, sold, or otherwise transferred to another individual or repository without the written permission of The Museum of Modern Art Archives.

When publication is intended, publication-quality images must be obtained from SCALA Group, the Museum's agent for licensing and distribution of images to outside publishers and researchers.

If you wish to quote any of this material in a publication, an application for permission to publish must be submitted to the MoMA Archives. This stipulation also applies to dissertations and theses. All references to materials should cite the archival collection and folder, and acknowledge "The Museum of Modern Art Archives, New York."

Whether publishing an image or quoting text, you are responsible for obtaining any consents or permissions which may be necessary in connection with any use of the archival materials, including, without limitation, any necessary authorizations from the copyright holder thereof or from any individual depicted therein.

In requesting and accepting this reproduction, you are agreeing to indemnify and hold harmless The Museum of Modern Art, its agents and employees against all claims, demands, costs and expenses incurred by copyright infringement or any other legal or regulatory cause of action arising from the use of this material.

NOTICE: WARNING CONCERNING COPYRIGHT RESTRICTIONS

The copyright law of the United States (Title 17, United States Code) governs the making of photocopies or other reproductions of copyrighted material. Under certain conditions specified in the law, libraries and archives are authorized to furnish a photocopy or other reproduction. One of these specified conditions is that the photocopy or reproduction is not to be "used for any purpose other than private study, scholarship, or research." If a user makes a request for, or later uses, a photocopy or reproduction for purposes in excess of "fair use," that user may be liable for copyright infringement.

FOR STUDY PURPOSES ONLY. NOT FOR REPRODUCTION.

The Museum of Modern Art Archives, NY	Collection:	Series.Folder:
	Burton	IV.48



FOR STUDY PURPOSES ONLY. NOT FOR REPRODUCTION.

The Museum of Modern Art Archives, NY	Collection:	Series.Folder:
	Burton	IV.48



FOR STUDY PURPOSES ONLY. NOT FOR REPRODUCTION.

The Museum of Modern Art Archives, NY	Collection:	Series.Folder:
	Burton	IV.48

Nancy Drysdale
Destroyed
Cafe Table
11/19/89

FOR STUDY PURPOSES ONLY. NOT FOR REPRODUCTION.

The Museum of Modern Art Archives, NY	Collection:	Series.Folder:
	Burton	IV.48

Max Protetch

560 Broadway
New York 10012
212.966.5454

10/27/89

HMB Art Transfer, Inc
1741 Johnson Avenue, NW
Washington D.C. 20009

INVOICE

To: Storage of Scott Burton 'Cafe Table'
at Crozier warehouse, 541 West 21st. Stree,
NY NY for 12 months @ \$20.00 per month.

\$240.00

Release Fee

\$ 30.00

TOTAL:

\$270.00

Please make checks payable to: MAX PROTETCH INC.

Thank you.

The Museum of Modern Art Archives, NY	Collection:	Series.Folder:
	Burton	IV.48

McIntosh / Drysdale

(202) 244-2988

NINA FELS

22-4918

I, Scott Burton, owe Nancy Drysdale the sum of \$3900.00 for her initial investment of the fabrication costs of "The Slat Chair." I agree to reimburse her in full no later than one year from this date and sooner if possible.

October

Nancy
3540 O
Washir

Dear N:

Enclose
\$3,900

Since w
for Jack
I am w
storing

Hope y

Sincere

M

Nina Fe

Scott burton Date

pd \$2,000 July/84
pd \$1,900 10/19/89

3540 Ordway Street, N. W. • Washington, D. C. 20016

MAX PROTETCH, INC.		2928
560 BROADWAY, 2ND FL. NEW YORK, NY 10012		1-B 210518
PAY TO THE ORDER OF	<i>Nancy Drysdale</i>	10.17.89 19
	<i>One thousand Nine Hundred</i>	\$ 1,900 --
		DOLLARS
Citibank, N.A. 130 East 42nd Street New York, N.Y. 10017	CITICORP CITIBANK Private Banking	<i>Max Protetch</i>
FOR <i>S. Burton</i>		
⑈002928⑈ ⑈021000089⑈ 518 34552153⑈		

FOR STUDY PURPOSES ONLY. NOT FOR REPRODUCTION.

The Museum of Modern Art Archives, NY	Collection:	Series.Folder:
	Burton	IV.48

NINA FELSHIN 27 WEST 96TH STREET NEW YORK NY 10025 (212) 222-4918

October 19, 1989

Nancy Drysdale
3540 Ordeway Street, NW
Washington, D.C. 20016

Dear Nancy:

Enclosed is a check for \$1,900.00, the balance of your loan to Scott of \$3,900.00.

Since we (HMB, The Protetch Gallery and I) do not have a current number for Jack Ring, plans for shipping the work to Washington have been stalled. I am waiting to hear how to proceed. I must also receive payment for storing the table for twelve months from HMB before we can release it.

Hope you had a wonderful trip.

Sincerely,

Nina Felshin

MAX PROTETCH, INC. 560 BROADWAY, 2ND FL. NEW YORK, NY 10012		2928
PAY TO THE ORDER OF <u>Nancy Drysdale</u>		10-17-89 19 ¹⁻⁸ / ₂₁₀ 518
<u>One thousand nine hundred</u>		\$ 1,900 - 00
CITIBANK, N.A. 130 East 42nd Street New York, N.Y. 10017		DOLLARS
FOR <u>S. Burton</u>	CITICORP + CITIBANK Private Banking	<u>Max Protetch</u>
⑈002928⑈ ⑆021000089⑆ 518 34552153⑈		

FOR STUDY PURPOSES ONLY. NOT FOR REPRODUCTION.

The Museum of Modern Art Archives, NY	Collection:	Series.Folder:
	Burton	IV.48

NINA FELSHIN 27 WEST 96TH STREET NEW YORK NY 10025 (212) 222-4918

October 17, 1989

Mike Bliss
Max Protetch Gallery
560 Broadway
New York, NY 10012

Dear Mike:

Scott has requested a check in the amount of \$1,900.00, payable to Nancy Drysdale to repay her for fabrication costs. This amount represents the balance of a \$3,900.00 loan.

Many thanks for taking care of this.

Sincerely,

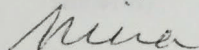

Nina Felshin

FOR STUDY PURPOSES ONLY. NOT FOR REPRODUCTION.

The Museum of Modern Art Archives, NY	Collection:	Series.Folder:
	Burton	IV.48

July 25, 1989

Nancy A. Drysdale
3540 Ordway Street, NW
Washington, DC 20016

Dear Nancy:

Enclosed is a check for \$2,000.00 in partial payment of the loan of \$3,900.00. Scott's a bit strapped at the moment with IRS debts. As soon as he receives the balance of the HMB payment he will forward your balance to you.

He had a great trip out West. Now he's off to Europe to prepare for the opening of the Stuttgart Kunstverein show.

Sincerely,

Nina Felshin

Encl.

FOR STUDY PURPOSES ONLY. NOT FOR REPRODUCTION.

The Museum of Modern Art Archives, NY	Collection:	Series.Folder:
	Burton	IV.48

McIntosh/Drysdale

3540 Ordway Street, N.W.
Washington, D. C. 20016
(202) 244-2988

July 11, 1989

Mr. Scott Burton
360 W. 36th St.
New York, N.Y. 10018

Dear Scott:

HMB SHIPPERS INFORM ME THAT THE INSURANCE COMPANY IS PAYING FOR THE REPLACEMENT TABLE. I HOPE YOU SEE A CHECK SOON. I AM MOST APOLOGETIC ABOUT THIS MESS AND HOPE IT IS SETTLED SOON.

I am writing to to remind you about the loan of \$3900.00 for the fabrication of the slat chair which is now due. I would be very happy to apply that sum to the purchase of a work of yours. If this is of interest let me know what is available and see if we can't work something out.

Hope you have had an interesting vacation in the South-West. It is a truly amazing area of our country. Doug and I spent a glorious time in Greece in May and wonder how we have lived so long without seeing that beautiful country.

I look forward to hearing from you and seeing that new table in place.

Very truly,

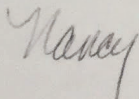

Nancy A. Drysdale

FOR STUDY PURPOSES ONLY. NOT FOR REPRODUCTION.

The Museum of Modern Art Archives, NY	Collection:	Series.Folder:
	Burton	IV.48

NINA FELSHIN 27 W 96TH STREET NEW YORK NY 10025 (212) 222-4918

May 13, 1988

Sally Meeker
HMB Art Transfer, Inc.
1741 Johnson Avenue, NW
Washington, D.C. 20009

Dear Sally,

Enclosed is the bill for the refabrication of Nancy's Cafe Table I. Please verify in writing that it is 10/10 in the edition. I got that information from either you or Nancy, but can't find any record of it in Scott's own files.

Many thanks.

Sincerely,

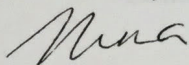

Nina Felshin

FOR STUDY PURPOSES ONLY. NOT FOR REPRODUCTION.

The Museum of Modern Art Archives, NY	Collection:	Series.Folder:
	Burton	IV.48

Scott Burton
360 West 36th Street
Apartment 8 South
New York, New York 10018

May 13, 1988

HMB Art Transfer, Inc.
1741 Johnson Avenue, NW
Washington, D.C. 20009

I N V O I C E

Replacement of:

Cafe Table I, 1984-87 (Refabricated in 1988)
Polished granite (Black Impala)
28 x 22 x 22
Edition: 10/10

\$ 4,000.00

paid

Authorized by *Scott Burton*
Date *5-13-88*

The Museum of Modern Art Archives, NY	Collection:	Series.Folder:
	Burton	IV.48

6/2/89

Bell Hill

Nancy didn't request insurance

so covered for only \$.60 a period.

What they've paid would cover that.

Nancy wanted them to be fully responsible

Wash insur. Company very bureaucratic. Don't know what they're doing

FOR STUDY PURPOSES ONLY. NOT FOR REPRODUCTION.

The Museum of Modern Art Archives, NY	Collection:	Series.Folder:
	Burton	IV.48

HMB ART TRANSFER, INC.

1741 Johnson Avenue, N.W.
Washington, D.C. 20009
(202) 387-8468

*rec'd 3 us of
epf 2/6*

December 31, 1988

Mr. Scott Burton
360 West 36th St. #8 South
New York, New York 10018

Dear Mr. Burton:

The enclosed check for \$800.00 is the first of five installments totalling \$4,000.00 for the cost of refabricating Cafe Table I Edition 10/10. Each subsequent payment will be made on a weekly basis. This schedule is shorter than the most recent proposal made to Nina Felshin.

Please forgive the delay but we have been royally screwed by our insurance company and our agent.

Nina has been delightful to deal with in this unfortunate situation

Sincerely,

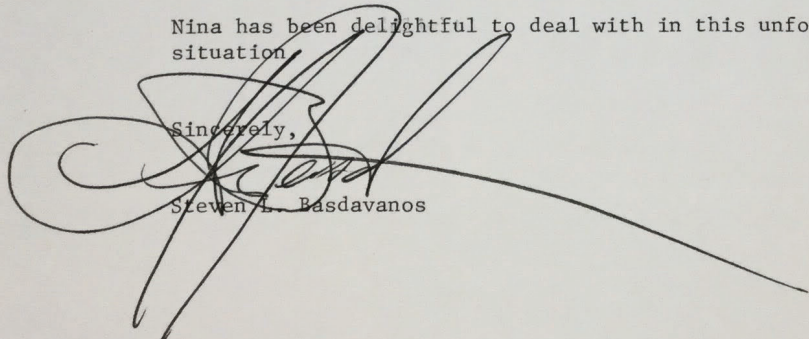
Steven L. Basdavanos

The Museum of Modern Art Archives, NY	Collection:	Series.Folder:
	Burton	IV.48

1/10
SB - rec'd 1st payment \$1800

Capt. Talle del to Crozier

M.H. Storage

Crozier Fine Art

541 W 21st St

Joseph 741-7853

\$1931.00 call to SB 36 St

Sally HMB transfer

(202) 387-8468

Mr. Steve - Stony Hact

(301) 345-2272

8101 River Rd

Bethesda

The Museum of Modern Art Archives, NY	Collection:	Series.Folder:
	Burton	IV.48

Suzanne Rofa

800 421-0166

Tues. Nov 1

Cafe Table del to Crozier

M.P. Storage

Crozier Fine Art

541 W. 21st St

Joseph 741-7853

\$1,931.00 bill to SB - 36 St

Sally HMB transfer

(202) 387-8468

Mr. Stone - Stony Hurst

(301) 365-2272

8101 River Rd
Bethesda,

The Museum of Modern Art Archives, NY	Collection:	Series.Folder:
	Burton	IV.48

Cafe Table I 1987

28 x 24 x 24

Yellow Freight
del. to Crozier

Max Protected Storage
Crozier Fine Art
541 W 21 St

forklift Joseph - 741-7853

FOR STUDY PURPOSES ONLY. NOT FOR REPRODUCTION.

The Museum of Modern Art Archives, NY	Collection:	Series.Folder:
	Burton	IV.48

Cafe Table I 1987

28 x 24 x 24

Black Impala

10/10

\$ 20,000

HMB transfer
(202) 387-8468

Nina Felshin

FOR STUDY PURPOSES ONLY. NOT FOR REPRODUCTION.

The Museum of Modern Art Archives, NY	Collection:	Series.Folder:
	Burton	IV.48

NINA FELSHIN 27 W 96TH STREET NEW YORK NY 10025 (212) 222-4918

May 2, 1988

Mr. Dennis Merchant
Rock of Ages
P.O. box 482
Barre, Vermont 05641

Dear Mr. Merchant,

Enclosed is the drawing for Cafe Table I. As per our order of April 18, it is to be made of Black Impala granite and billed to the Max Protetch Gallery.

Our apologies for the confusion regarding this. If you have any further questions, please feel free to contact me or Scott.

Thanks.

Sincerely,

Nina Felshin

FOR STUDY PURPOSES ONLY. NOT FOR REPRODUCTION.

The Museum of Modern Art Archives, NY	Collection:	Series.Folder:
	Burton	IV.48

NINA FELSHIN 27 W 96TH STREET NEW YORK NY 10025 (212) 222-4918

April 18, 1988

Dennis Merchant
Rock of Ages
P.O. Box 482
Barre, VT 05641

Dear Mr. Merchant:

At Scott Burton's request I am writing to formally order a duplicate of the Black Impala Cafe Table I that you made in 1987. Please bill the Max Protetch Gallery for this work.

If you have any questions or need additional information I can be reached at the above number.

Sincerely,

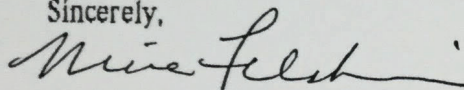

Nina Felshin

cc: Michael Bliss
Max Protetch Gallery

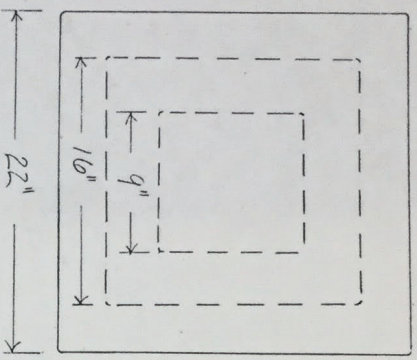

TOP.

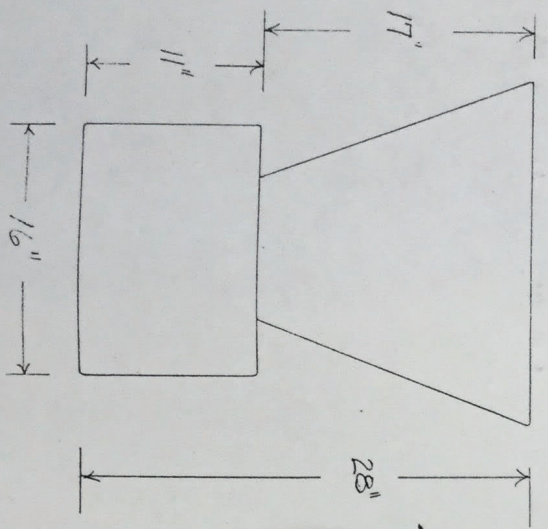

• SIDES.

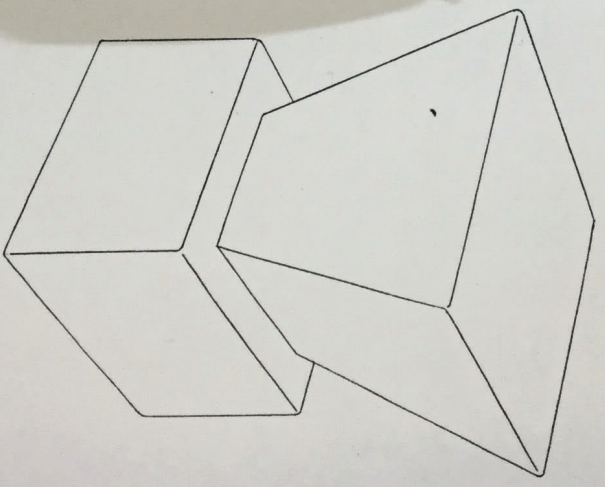
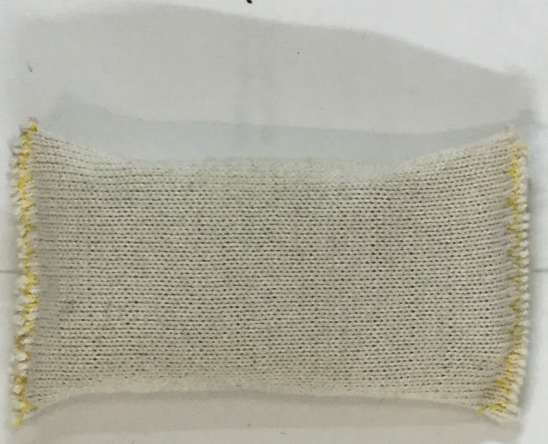

• CAFE TABLE I. POLISHED GRANITE.
 • TWO PARTS. STAINLESS STEEL PINS WITH
 EPOXY CONNECTION. 1/16" RADII, ALL EDGES,
 • POLISH ALL EXPOSED SURFACES.

SCOTT BURTON

SCALE: 1/8" = 1" - T.A.M.

FOR STUDY PURPOSES ONLY. NOT FOR REPRODUCTION.

The Museum of Modern Art Archives, NY	Collection:	Series.Folder:
	Burton	IV.48

NINA FELSHIN 27 W 96TH STREET NEW YORK NY 10025 (212) 222-4918

April 18, 1988

Dennis Merchant
Rock of Ages
P.O. Box 482
Barre, VT 05641

Dear Mr. Merchant:

At Scott Burton's request I am writing to formally order a duplicate of the Black Impala Cafe Table I that you made in 1987. Please bill the Max Protetch Gallery for this work.

If you have any questions or need additional information I can be reached at the above number.

Sincerely,

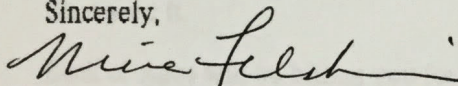

Nina Felshin

cc: Michael Bliss
Max Protetch Gallery

FOR STUDY PURPOSES ONLY. NOT FOR REPRODUCTION.

The Museum of Modern Art Archives, NY	Collection:	Series.Folder:
	Burton	IV.48

NINA FELSHIN 27 W 96TH STREET NEW YORK NY 10025 (212)222-4918

April 18, 1988

Michael Bliss
Max Protetch Gallery
560 Broadway
New York, NY 10012

Dear Michael:

The table I've ordered in the enclosed copy of my letter to Rock of Ages is the replacement for the Nancy Drysdale Cafe Table I that was damaged.

Scott also asked me to order a duplicate of Cafe Table II in laurentian pink and gray. I'm holding off on that until we resolve some questions as to how many of them now exist. Larry can explain this further as we've already discussed it.

Rock of Ages will be billing you for this. Max has agreed to deduct it from Scott's account. It will cost approximately \$2,000.00. When and if the other duplicate is ordered it will also be billed to the gallery.

If you have any questions feel free to call.

Sincerely,

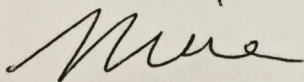

Nina

The Museum of Modern Art Archives, NY	Collection:	Series.Folder:
	Burton	IV.48

JB. re - Ouydale

OK if Mr. Stone witnesses
destruction. Before and
after photo?

or get Registrar from
a local museum

Jack Noy: installer

Order table.

The Museum of Modern Art Archives, NY	Collection:	Series.Folder:
	Burton	IV.48

My notes from Scott

2/25/88 Cafe Table ^I#56 in catalog - Nancy
No. 7/10?

Tell Larry re: Cafe Table II
SB ordered 2 Cafe Table II.
MP will be billed + will
be deducted from his next bill.

3/19 Michael - Order 2 me. Rock of Ages.
Mike to do Make sure 2 cafe tables
get ordered thru Rock of Ages.
Duper 1 Nancy
1 for a friend
Bill to MP. Deduct from SB.

Larry
Rock of Ages has never made Cafe
Table I. - would not have drawing
unless you gave it to them.

Q.
Cafe Tables made or in progress are II +
all 2 colors

The Museum of Modern Art Archives, NY	Collection:	Series.Folder:
	Burton	IV.48

(301) 365-2272
 Stony Hurst Quarry
 Bethesda.
 OK to have
 destroyed these

FAE Nancy -

April 6, 1988

At quarry - crane will be used
 to load onto truck. No
 extra men needed

Work will be crated.
 will need to be ^{hooked} strapped to floor

Delivered to residence at 3540 Ordway
 No help available at house NW

Nancy

(202) 783-5190

Inside house on 1st floor
 Easy access from street

28x24x24

Weight according to MPG - 800 lbs.

Barre. ¹²/₁₇

Rock of Ages Dennis Merchant
 (800) 476-3115
 1-800-421-0166

- 2 chairs
 - 1 chair
 - 2 cafe tables II
 - 2 - tops
 - 1 cafe table
 - 2 tops.
- (Oct 27 - confirm
 Laurentian pink)

Dec 4 1987 - asked for
 quote on black
 + grey (larry) but
 didn't order.

FOR STUDY PURPOSES ONLY. NOT FOR REPRODUCTION.

The Museum of Modern Art Archives, NY	Collection:	Series.Folder:
	Burton	IV.48

NINA FELSHIN 27 W 96TH STREET NEW YORK NY 10025 (212) 222-4918

April 8, 1988

Nancy Drysdale
McIntosh/Drysdale Gallery
406 Seventh Street NW
Washington, D.C. 20004

Sally (202) 387-8468

Dear Nancy,

When I spoke with Sally Minker of HMB Art Transfer, she suggested I provide you with the costs involved in my coming down to Washington to witness the destruction of the cafe table. She reminded me that the insurance company will need this information to process the claim.

In addition to the cost of shipping the new work to Washington, which I am now looking into, please inform the insurance company of the cost of trucking the damaged work to Scott's quarry in Bethesda.

Enclosed please find my invoice. My fee is based on the hourly rate at which Scott pays me.

Many thanks for taking care of this.

Sincerely,

Nina Felshin

*copy to Sally Minker
HMB Transfer
1741 Johnson Ct NW 20009*

FOR STUDY PURPOSES ONLY. NOT FOR REPRODUCTION.

The Museum of Modern Art Archives, NY	Collection:	Series.Folder:
	Burton	IV.48

NINA FELSHIN 27 W 96TH STREET NEW YORK NY 10025 (212) 222-4918

April 8, 1988

Nancy Drysdale
McIntosh/Drysdale Gallery
406 Seventh Street NW
Washington, D.C. 20004

I N V O I C E

RE: Expenses for trip to Washington D.C. to witness destruction of Scott
Burton's damaged cafe table

For professional services:
8 hours @ \$45.00 \$ 360.00

Expenses:
Train fare (NY-DC-NY) 112.00
Taxis 45.00
Food/Misc. expenses 15.00 172.00

TOTAL AMOUNT DUE \$ 532.00

FOR STUDY PURPOSES ONLY. NOT FOR REPRODUCTION.

The Museum of Modern Art Archives, NY	Collection:	Series.Folder:
	Burton	IV.48

Scott Burton
360 West 36th Street
Apartment 8 South
New York, NY 10018

February 26, 1988

Ms. Nancy Drysdale
McIntosh/Drysdale Gallery
406 Seventh Street NW
Washington, D.C. 20004

Dear Nancy,

I am writing to confirm that you purchased the following work from me for the sum of \$10,000.00:

Cafe Table, design 1984, fabrication 1987
polished granite
28 x 22 x 22
edition: 7/10

If you need any further information, please do not hesitate to contact me.

Sincerely,

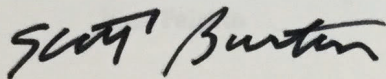

Scott Burton

FOR STUDY PURPOSES ONLY. NOT FOR REPRODUCTION.

The Museum of Modern Art Archives, NY	Collection:	Series.Folder:
	Burton	IV.48

NINA FELSHIN 27 W 96TH STREET NEW YORK NY 10025 (212) 222-4918

*Cafe Table I
Absolute Black*

March 11, 1988

Nancy Drysdale
McIntosh/Drysdale Gallery
406 Seventh Street NW
Washington, D.C. 20004

Dear Nancy,

Scott and I have discussed the disposition of the damaged cafe table. He would like it to be destroyed in his or my presence or in the presence of a third party of his choosing.

We'll figure out the details and be back in touch. For now, I wanted you to at least know our general plan.

Sincerely,

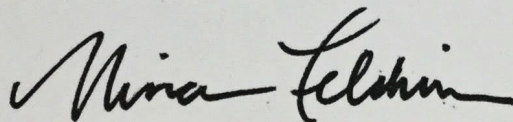

Nina Felshin